

Dial Indicator Applications

Comparison measuring instruments which ensure high quality, high accuracy and reliability.

Dial Snap Gage

- Designed for quick GO/NG judgment of diameters of cylinders and shafts in machining processes.
- Wide (13.5 x 12 mm / 1.53 x 47 inch), flat carbide anvils.
- Anvil retracting stroke: 2 mm / 0.08 inch
Anvil positioning range: 25 mm / 1 inch
- Adjustment nut: adjusts the measuring range.
- Clamp: adjustment nut
- Flatness of measuring face: 1 μm
- Repeatability of indication: 2 μm or less (repeatability of indicators is not included)
- The dial indicator and protection cover are optional. Also, some dial indicators and protection covers cannot be used with the dial snap gage. Consult Mitutoyo if intending to use dial indicators which are not recommended.

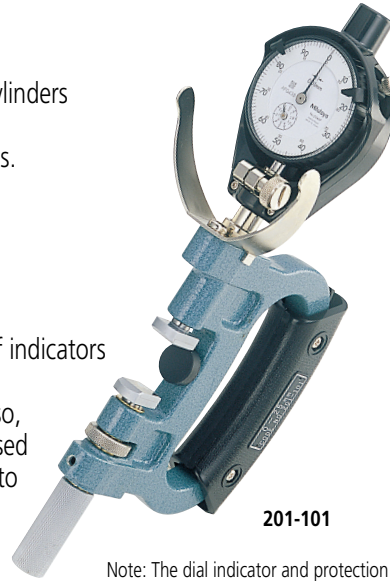

201-101

Note: The dial indicator and protection cover are optional.

SPECIFICATIONS

Metric				
Order No.	Range	Parallelism	Measuring force	Recommended dial indicator (optional)
201-101	0 - 25 mm	5 μm	15 N±3 N	2046SB (0.01 mm reading), 2109SB-10 (0.001 mm reading)
201-102	25 - 50 mm	5 μm	15 N±3 N	2046SB (0.01 mm reading), 2109SB-10 (0.001 mm reading)
201-103	50 - 75 mm	5 μm	15 N±3 N	2046SB (0.01 mm reading), 2109SB-10 (0.001 mm reading)
201-104	75 - 100 mm	5 μm	15 N±3 N	2046SB (0.01 mm reading), 2109SB-10 (0.001 mm reading)
201-105	100 - 125 mm	5 μm	15 N±3 N	2046SB (0.01 mm reading), 2109SB-10 (0.001 mm reading)
201-106	125 - 150 mm	5 μm	15 N±3 N	2046SB (0.01 mm reading), 2109SB-10 (0.001 mm reading)
201-107	150 - 175 mm	5 μm	15 N±3 N	2046SB (0.01 mm reading), 2109SB-10 (0.001 mm reading)
201-108	175 - 200 mm	5 μm	15 N±3 N	2046SB (0.01 mm reading), 2109SB-10 (0.001 mm reading)
201-109	200 - 225 mm	5 μm	15 N±3 N	2046SB (0.01 mm reading), 2109SB-10 (0.001 mm reading)
201-110	225 - 250 mm	5 μm	15 N±3 N	2046SB (0.01 mm reading), 2109SB-10 (0.001 mm reading)
201-111	250 - 275 mm	5 μm	15 N±3 N	2046SB (0.01 mm reading), 2109SB-10 (0.001 mm reading)
201-112	275 - 300 mm	5 μm	15 N±3 N	2046SB (0.01 mm reading), 2109SB-10 (0.001 mm reading)

Inch				
Order No.	Range	Parallelism	Measuring force	Recommended dial indicator (optional)
201-151	0 - 1 in	0.0002 in	15 N±3 N	2803SB-10 (0.0001 inch reading)
201-152	1 - 2 in	0.0002 in	15 N±3 N	2803SB-10 (0.0001 inch reading)
201-153	2 - 3 in	0.0002 in	15 N±3 N	2803SB-10 (0.0001 inch reading)
201-154	3 - 4 in	0.0002 in	15 N±3 N	2803SB-10 (0.0001 inch reading)
201-155	4 - 5 in	0.0002 in	15 N±3 N	2803SB-10 (0.0001 inch reading)
201-156	5 - 6 in	0.0002 in	15 N±3 N	2803SB-10 (0.0001 inch reading)
201-157	6 - 7 in	0.0002 in	15 N±3 N	2803SB-10 (0.0001 inch reading)
201-158	7 - 8 in	0.0002 in	15 N±3 N	2803SB-10 (0.0001 inch reading)
201-159	8 - 9 in	0.0002 in	15 N±3 N	2803SB-10 (0.0001 inch reading)
201-160	9 - 10 in	0.0002 in	15 N±3 N	2803SB-10 (0.0001 inch reading)
201-161	10 - 11 in	0.0002 in	15 N±3 N	2803SB-10 (0.0001 inch reading)
201-162	11 - 12 in	0.0002 in	15 N±3 N	2803SB-10 (0.0001 inch reading)

*1: Measuring force is that force present before an indicator is installed and is determined at the point where the spindle is retracted 1 mm from the rest position.

DIMENSIONS

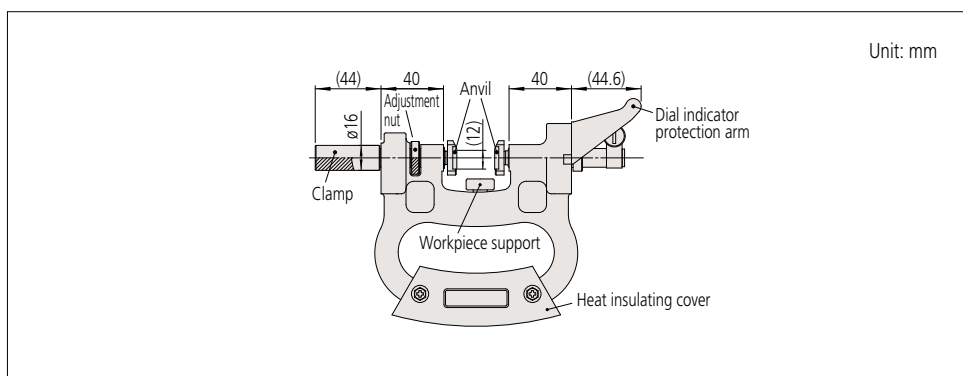

Optional accessories

Dial indicator
Dial protection cover: **No.21DZA000**
Refer to page C-45 for details.

Recommended dial indicators

No.2046SB: Dial indicator (Graduation: 0.01 mm)
No.2109SB-10: Dial indicator (Graduation: 0.001 mm)